

Custom Two-Way Crossover Network Design

By Dr F. Mark Carter, Walberswick Studios

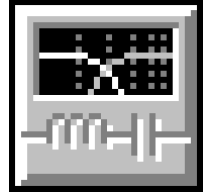

3-Way Crossover Network

Low-Pass (LP) Filter: 1 required

Type: 2nd-Order All-Pass (APC)

Desired Corner Frequency: 350 Hz

Band-Pass (BP) Filter: 1 required

Type: 2nd-Order All-Pass (APC)

Desired Lower Corner Freq: 350 Hz

Desired Upper Corner Freq: 3000 Hz

High-Pass (HP) Filter: 1 required

Type: 2nd-Order All-Pass (APC)

Desired Corner Frequency: 3000 Hz

C1 = 4 μ F, Polypropylene, 0.00743 ohms

C2 = 40 μ F, Polypropylene, 0.00275 ohms

C3 = 2 μ F, Polypropylene, 0.00767 ohms

C4 = 40 μ F, Polypropylene, 0.00264 ohms

L1 = 0.8 mH, Air Core (#16), 0.338 ohms

L2 = 8 mH, Air Core (#16), 1.036 ohms

L3 = 0.5 mH, Air Core (#16), 0.331 ohms

L4 = 5 mH, Air Core (#16), 0.818 ohms

R1 = 2 ohms

Tweeter

7.12 dB L-Pad

Rp1 = 4 ohms

Rp2 = 10 ohms

Midrange

Impedance EQ

Req = 6 ohms

Ce = 10 μ F

Woofer

Impedance EQ

Req = 6 ohms

Ce = 100 μ F

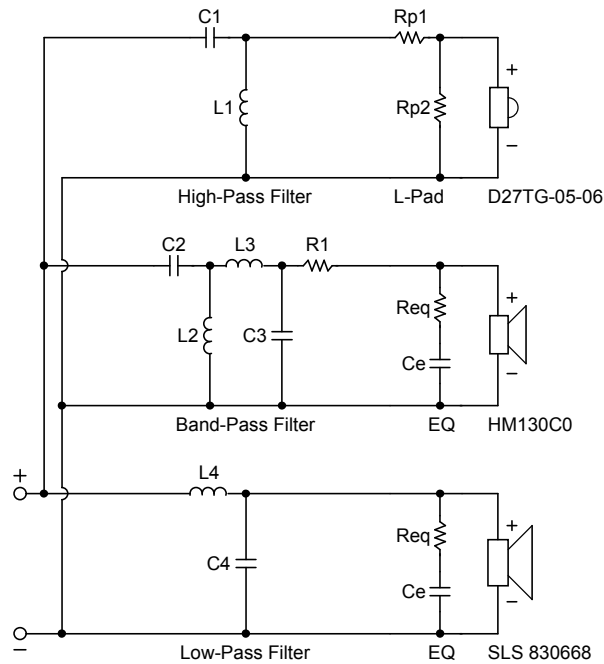



Tweeter Properties

--Driver Description--

Name: D27TG-05-06
 Type: Standard one-way driver
 Company: Vifa

--Driver Configuration--

No. of Drivers = 1

--Driver Parameters--

Fs = 1000 Hz
 Qms = 2.15
 Vas = 0.006 liters
 Mms = 0.3 g
 Xmax = 0.15 mm
 Sd = 7.1 sq.cm
 Qes = 1.19
 Re = 4.6 ohms
 Le = 0.0481 mH
 Z = 6 ohms
 BL = 2.7 Tm
 Pe = 100 watts
 Qts = 0.77
 1-W SPL = 91 dB
 2.83-V SPL = 92 dB

Midrange Properties

--Driver Description--

Name: HM130CO
 Type: One-way open back driver
 Company: Audax Industries

Comment: Reference series

--Driver Configuration--

No. of Drivers = 1

--Driver Parameters--

Fs = 46 Hz
 Qms = 3.6
 Vas = 18.1 liters
 Cms = 1.78 mm/N
 Mms = 6.9 g
 Rms = 0.55 kg/s
 Xmax = 3 mm
 Sd = 85 sq.cm
 Qes = 0.34
 Re = 6.2 ohms
 Le = 0.39 mH
 Z = 8 ohms
 BL = 5.97 Tm
 Pe = 50 watts
 Qts = 0.31
 1-W SPL = 90 dB

Woofers Properties

--Driver Description--

Name: SLS 830668
 Type: Standard one-way driver
 Company: Peerless (Denmark)

--Driver Configuration--

No. of Drivers = 1

--Driver Parameters--

Fs = 33.3 Hz
 Qms = 4.85
 Vas = 69.3 liters
 Cms = 0.45 mm/N
 Mms = 51.1 g
 Rms = 2.19 kg/s
 Xmax = 8 mm
 Xmech = 12 mm
 P-Dia = 207 mm
 Sd = 335 sq.cm
 P-Vd = 0.263 liters
 Qes = 0.57
 Re = 5.6 ohms
 Le = 3.3 mH
 Z = 8 ohms
 BL = 10.2 Tm
 Pe = 100 watts
 Qts = 0.51
 no = 0.433 %
 1-W SPL = 88.51 dB
 2.83-V SPL = 88.7 dB

Graph Key: LP BP HP Net

