

Custom Two-Way Crossover Network Design

By Dr F. Mark Carter, Walberswick Studios

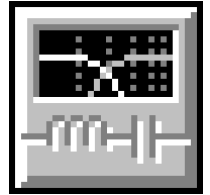

2-Way Crossover Network

Low-Pass (LP) Filter: 1 required

Type: 3rd-Order Butterworth

Desired Corner Frequency: 1250 Hz

High-Pass (HP) Filter: 1 required

Type: 3rd-Order Butterworth

Desired Corner Frequency: 1250 Hz

C1 = 12 μ F, Polypropylene, 0.00383 ohms

C2 = 35 μ F, Polypropylene, 0.00221 ohms

C3 = 60 μ F, Polypropylene, 0.00201 ohms

L1 = 0.25 mH, Air Core (#16), 0.3 ohms

L2 = 0.6 mH, Air Core (#16), 0.308 ohms

L3 = 0.3 mH, Air Core (#16), 0.269 ohms

Woofers

Impedance EQ

Req = 5 ohms

Ce = 25 μ F

Rm = 1.5 ohms

Cm = 1 mF

Lm = 9 mH

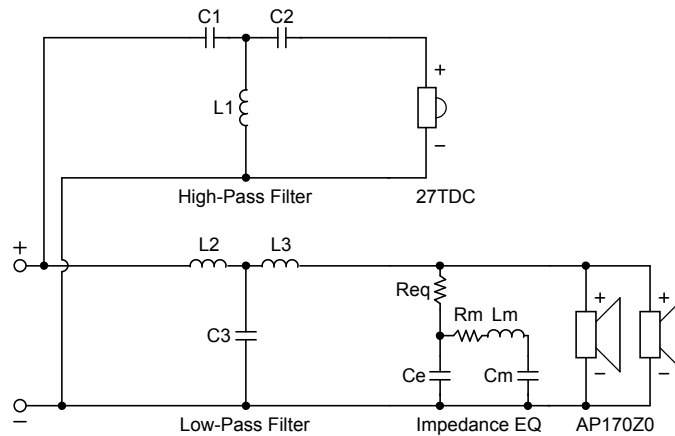



Tweeter Properties

--Driver Description--

Name: 27TDC
 Type: Standard one-way driver
 Company: Seas Fabrikker A.S.
 Comment: H 1149

--Driver Configuration--

No. of Drivers = 1

--Driver Parameters--

Fs = 550 Hz
 Qms = 0.972
 Vas = 0.0194 liters
 Cms = 0.279 mm/N
 Mms = 0.3 g
 Rms = 1.067 kg/s
 Xmax = 0.25 mm
 Xmech = 0.375 mm
 P-Dia = 29.85 mm
 Sd = 7 sq.cm
 P-Vd = 0.000175 liters
 Qes = 0.41
 Re = 4.8 ohms
 Le = 0.05 mH
 Z = 6 ohms
 BL = 3.5 Tm
 Pe = 55 watts
 Qts = 0.29
 no = 0.76 %
 1-W SPL = 90 dB
 2.83-V SPL = 93.17 dB

Woofers Properties

--Driver Description--

Name: AP170Z0
 Type: Standard one-way driver
 Company: Audax Industries

--Driver Configuration--

No. of Drivers = 2

Mounting = Standard

Wiring = Parallel

--Driver Parameters--

Fs = 48.5 Hz
 Qms = 1.61
 Vas = 24.65 liters [49.3]
 Cms = 0.996 mm/N [0.498]
 Mms = 10.82 g [21.64]
 Rms = 2.05 kg/s [4.1]
 Xmax = 3 mm
 Xmech = 4.5 mm
 P-Dia = 129.6 mm [183.3]
 Sd = 132.7 sq.cm [265.5]
 P-Vd = 0.0396 liters [0.0792]
 Qes = 0.5
 Re = 5.3 ohms [2.65]
 Le = 0.74 mH [0.37]
 Z = 6 ohms [3]
 BL = 5.76 Tm [5.912]
 Pe = 60 watts [120]
 Qts = 0.38
 no = 0.542 % [1.085]
 1-W SPL = 89.3 dB [92.31]
 2.83-V SPL = 91.28 dB [97.3]

Graph Key: — LP — HP — Net

