

Custom Three-Way Crossover Network Design

By Dr F. Mark Carter, Walberswick Studios

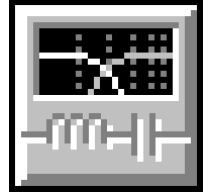

3-Way Crossover Network

Low-Pass (LP) Filter: 1 required

Type: 4th-Order All-Pass (APC)

Desired Corner Frequency: 250 Hz

Band-Pass (BP) Filter: 1 required

Type: 2nd-Order All-Pass (APC)

Desired Lower Corner Freq: 250 Hz

Desired Upper Corner Freq: 2000 Hz

High-Pass (HP) Filter: 1 required

Type: 2nd-Order All-Pass (APC)

Desired Corner Frequency: 2000 Hz

C1 = 6 μ F, , 0 ohms

C2 = omitted

C3 = 15 μ F, , 0 ohms

C4 = 30 μ F, Polypropylene, 0.00135 ohms

C5 = 10 μ F, Polypropylene, 0.00255 ohms

L1 = 0.25 mH, (#), 0 ohms

L2 = omitted

L3 = 1.5 mH, (#), 0 ohms

L4 = 7.5 mH, Air Core (#16), 0.927 ohms

L5 = 1 mH, Air Core (#16), 0.616 ohms

Tweeter

2.36 dB L-Pad

Rp1 = 1 ohms

Rp2 = 10 ohms

Midrange

Impedance EQ

Req = 5 ohms

Ce = 27 μ F

Rm = 1.5 ohms

Cm = 1.2 mF

Lm = 9 mH

Woofers

Impedance EQ

Req = 5 ohms

Ce = 27 μ F

Rm = 1.5 ohms

Cm = 1.2 mF

Lm = 9 mH

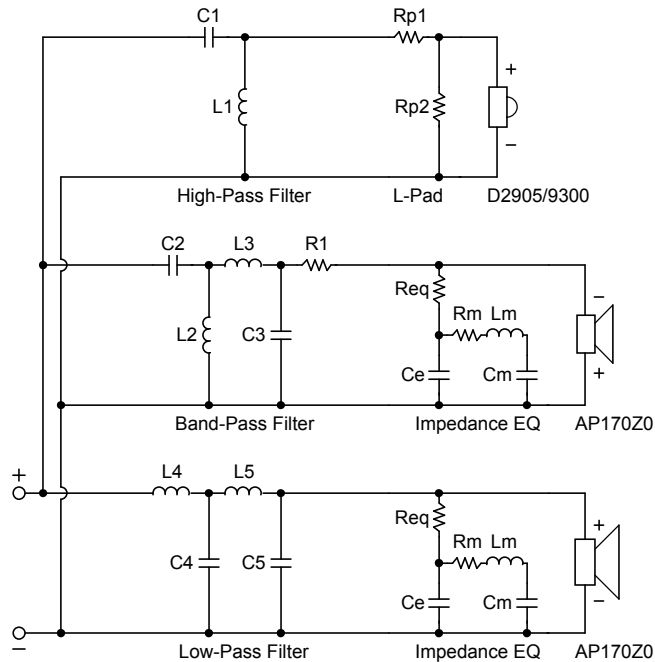



Tweeter Properties

--Driver Description--
 Name: D2905/9300
 Type: Standard one-way driver
 Company: Scan-Speak
 --Driver Configuration--

No. of Drivers = 1

--Driver Parameters--

Fs = 650 Hz
 Qms = 1.2
 Mms = 0.45 g
 Xmax = 0.4 mm
 Xmech = 1.5 mm
 Sd = 8.5 sq.cm
 Qes = 0.71
 Re = 4.7 ohms
 Le = 0.08 mH
 Z = 6 ohms
 BL = 3.5 Tm
 Pe = 150 watts
 Qts = 0.45
 2.83-V SPL = 90 dB

Midrange Properties

--Driver Description--
 Name: AP170Z0
 Type: One-way open back driver
 Company: Audax Industries
 --Driver Configuration--

No. of Drivers = 1

--Driver Parameters--

Fs = 48.5 Hz
 Qms = 1.61
 Vas = 24.65 liters
 Cms = 0.996 mm/N
 Mms = 10.82 g
 Rms = 2.05 kg/s
 Xmax = 3 mm
 Sd = 132.7 sq.cm
 Qes = 0.5
 Re = 5.3 ohms
 Le = 0.74 mH
 Z = 6 ohms
 BL = 5.76 Tm
 Pe = 60 watts
 Qts = 0.38
 1-W SPL = 89.3 dB

Woofers Properties

--Driver Description--
 Name: AP170Z0
 Type: Standard one-way driver
 Company: Audax Industries
 --Driver Configuration--

No. of Drivers = 1

--Driver Parameters--

Fs = 48.5 Hz
 Qms = 1.61
 Vas = 24.65 liters
 Cms = 0.996 mm/N
 Mms = 10.82 g
 Rms = 2.05 kg/s
 Xmax = 3 mm
 Sd = 132.7 sq.cm
 Qes = 0.5
 Re = 5.3 ohms
 Le = 0.74 mH
 Z = 6 ohms
 BL = 5.76 Tm
 Pe = 60 watts
 Qts = 0.38
 1-W SPL = 89.3 dB

Graph Key: LP BP HP Net

